

# Manual Hipot Tester Operation Manual

HM-GTB-3/50 AC Hipot Tester



## I. Summarize

HM-GTB-3/50 Power Frequency Withstand Voltage Test set is produced according to the Mechanical and Electrical Department based on similar products in the original after a lot of improvement and produced. TDM(G) series of light AC high-voltage test transformer is based on the YD series test transformer according to the national standards "ZBK-41006-89" through improved production of a new type of product. This series of products are with small volume, light weight, compact structure, functional, strong commonality and convenient use, etc., Especially suitable for power system, industrial and mining enterprises, scientific research departments and all kinds of pressure electric equipment, electric components, insulation material under high-voltage test. It's essential for high-voltage test equipment.

## II.Wiring Connection

### 1. Physical wiring diagram

#### 1) Wiring terminal on Control Box

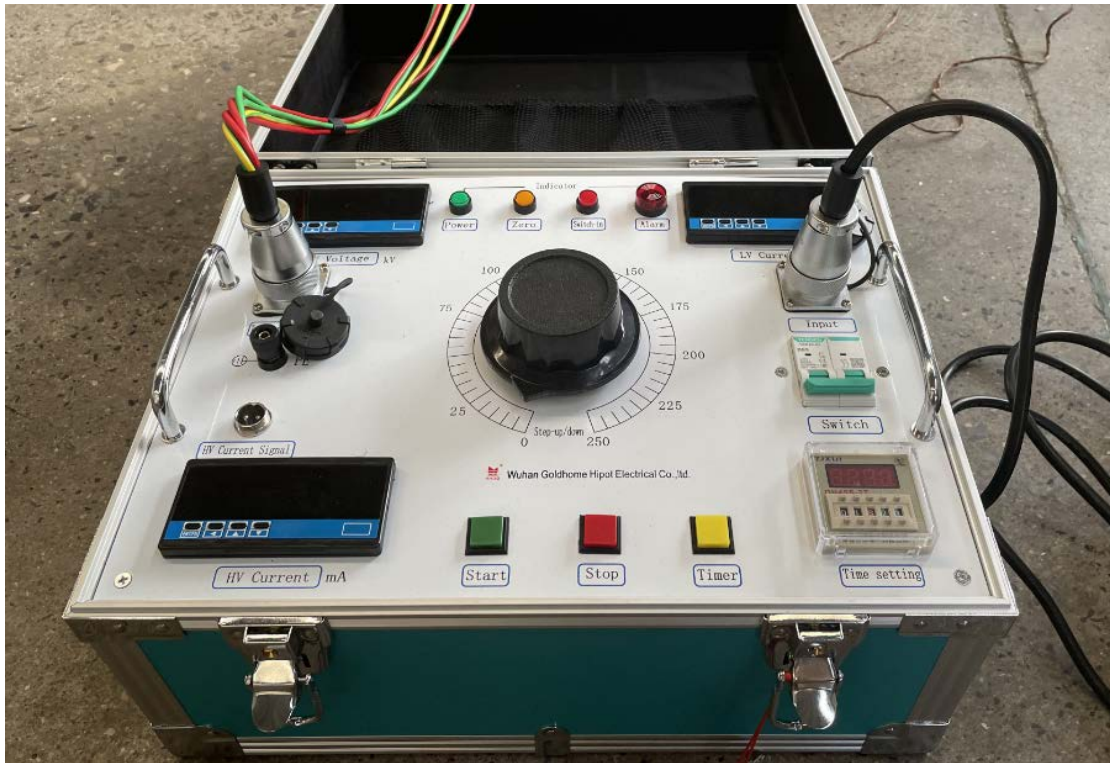

**Input :** connect with power supply in test lab

**To transformer :** connect with terminals on Test Transformer

**PE:** connect with grounding

**HV current signal :** connect with CT on Test transformer

## 2) Wiring terminal on dry type test transformer

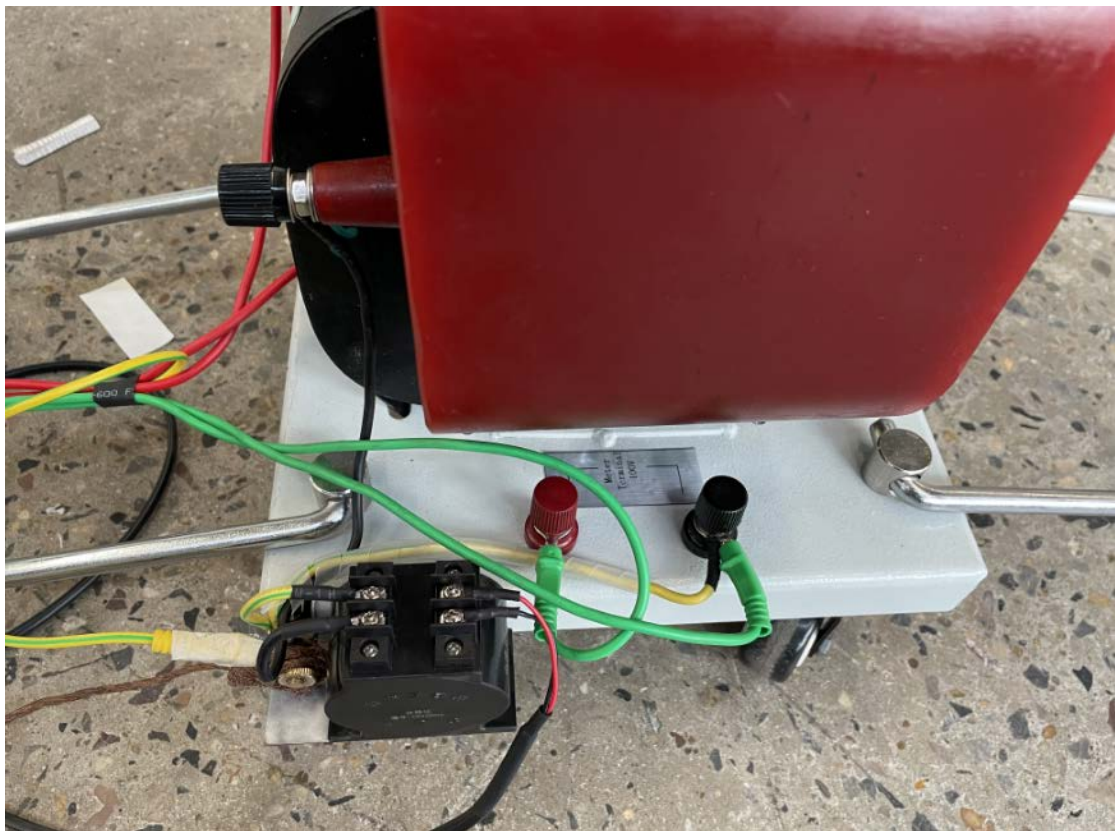
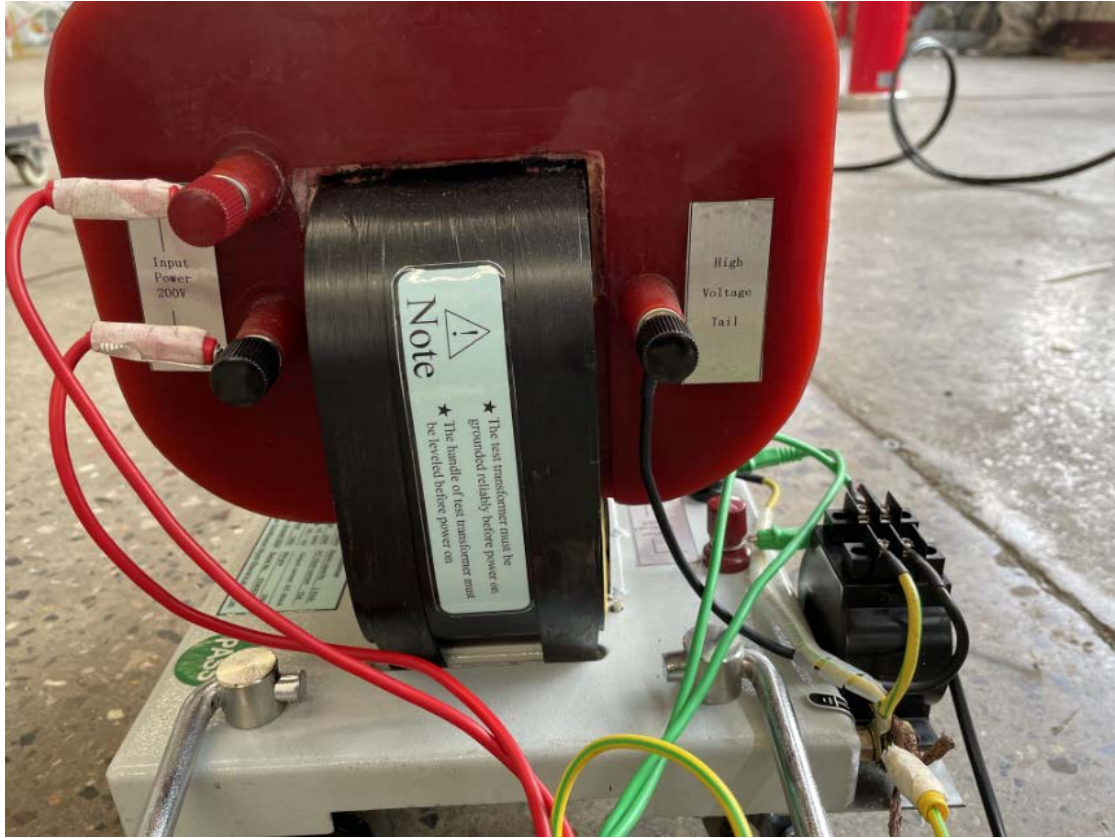

**Input Power side :** Connect with red cable

**High voltage tail :** connect with black cable from the CT

# ATO

**Meter terminal side** : connect with green cable.

**HV current signal on CT** : Connect with HV current signal from Control box

Yellow cable with narrow green (from the console ) : connect to the earth

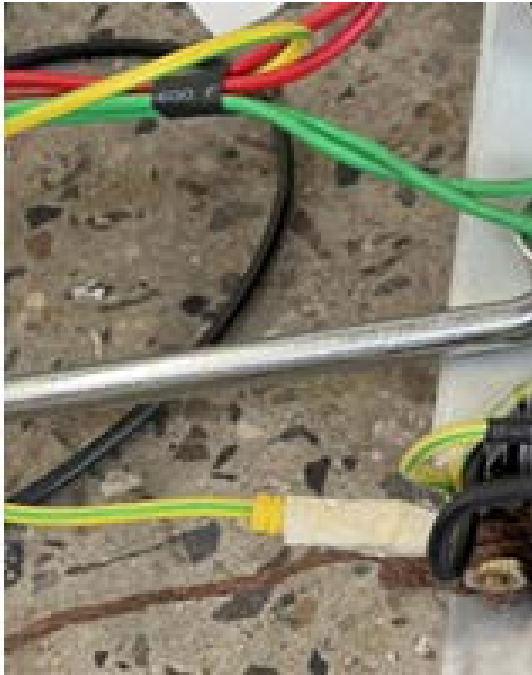

## II. Manual Control Box Introduction

### 1. Overview

This series of control box (console) is based on high-voltage test transformer's use of unique to design and produce, and its functions are:

- A, switch on sound and light alarms;
- B, time sound and light alarms;
- C, electronic low-voltage current protection (box);
- D, high voltage direct-reading;
- E, voltage withstand test of time free to set up (digital);
- F, mobile structures (desktop)

### 2. The working principles

This series of control box (console) is made up of a contact voltage regulator (electric voltage regulator above 50kVA column) and its controlling, protection, measurement, and signal circuit. It is through access to 220V or 380V AC power to regulate the voltage regulator (that is the input voltage of the test transformers), and to obtain the required value of test high voltage. Its working principles are shown as below:

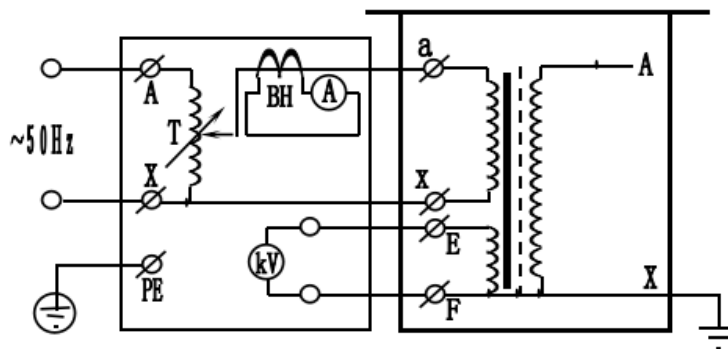

Figure 1: The working principle of controlling box(console)

BH - current transformer      (A) - ammeter

(kV) - high voltage display table      T - voltage regulator

### 3. Structure (Panel layout)





- **Power:**After the power is turned on, the “Power”indicator is on. At this time, if the voltage regulator is in the zero position (lower limit), the “zero” indicator is on. If it is not at the lower limit, the contactor is automatically sucked. In combination, the motor rotates to lower the regulator to zero position, the contactor is automatically released, and the “Zero” indicator light is on, and the power can be operated at this time.
- **Zero:** After the power is turned on , When the regulator is at 0, Zero indicator light will be on.
- **Withstand time setting:** you can set the testing time by manual.
- **Switch-in:** after you click the “Start”button, the “Switch-in ”indicate will be on. And when it is overcurrent, the “Switch-in”indicator will be off.
- **Alarm:** After click the “Start”button, “Alarm” indicate will be on. And when the withstanding time is arrived, the “Alarm” indicate will be on
- **HV Current:** high voltage current, it is directly read through gathering the date from testing transformer.
- **LV Current:**low voltage current.
- **High voltage:** the meter will display the required testing voltage
- **Start:** After the “Power” and “Zero”is on, and everything is ready for test, then click the “Start” Button.
- **Timer:** When the testing voltage is arrived at your required , then you can click the “Timer”,usually, hipot tester for 1 min
- **Stop:** After the test is finished, and let the regulator into 0, the click “Stop”.

## 4. Main parameter for 3kVA Control Box

- Rate capacity: 3kVA
- Input voltage: 220V/50Hz
- Input current: 13.6A
- Output voltage: 0~250V

## 5. Step guide

Before the operation was based on different sample capacity, voltage level, a good first calculate the maximum operating current, and adjust the current protection device. The pilot should refer to the manual wiring of Figure 1 or the relevant test transformer connection diagram, should be a good grounding grounding terminal (hereinafter, as the voltage test as an example).

1) Connected power supply (box-type for socket-type power supply, desktop power supply for the terminal), and voltage regulator to handle spin zero, the zero switch closed, the zero indicator (yellow) light, (also known as zero voltage regulator output status indication);

2) Press the start button (green), contactor pull-in, by the power regulator, while the work of light (red) light, and sound an alarm (siren left with zero voltage regulator, the police in order to stop the sound and light);

3) Clockwise rotation evenly slow regulator handle, and pay close attention to instrument readings, when high voltage to rise to the required value, should stop rotating hand-bing, and timely press the timer button (yellow), at this time, Digital display time relay time shun time (time units for the "s", seconds), when the arrival time set, control box (Taiwan) to issue sound and light alarm, time, voltage regulator handle rotating in the opposite direction until the transfer back to zero voltage, the time to lift button;

4) In the boost or voltage withstand test process, as a result of short circuit, flashover, breakdown, such as over-current, the current trip of relay protection, automatic voltage regulator power that test materials are not up to standard, at this time regulator should be back to zero, cutting off power supply, inspect the test products.

## 6. The use and maintenance

- When unpack to inspect ,we should check whether the controlling circuit wiring is loose, the brush of voltage regulator is in a good contact;



- Long-term when not in use, the use of pre-application form megohm 500V insulation resistance measurement, the value of not less than 0.5MΩ;
- Supply voltage should be in line with me (Taiwan) on the nameplate input voltage value;
- The Box (console) has over-current protection, the factory has been adjusted to 80% of rated current. For small loads, the test materials should be based on the rated capacity of the current re-setting;
- After use, should be close box (console) covered the door to keep me (console) internal cleaning.

## 7. The conditions of use

Environmental temperature :0-40 °C;

Altitude: <1000m;

Relative humidity: <85%;

Workplace should be no gas, steam, chemical dust which seriously affect the insulation and other explosive and corrosive media.

## III. Dry-type Test Transformer Introduction

### 1. Overview

The test also called transformer booster, which is used in areas of power supply equipment, all kinds of electrical products and tools and materials of insulation dielectric strength test.

Dry testing transformer series is produced, it is completely changed by the backward state of old test transformer stupid, big and heavy, it can produce our matching mounted on a high-voltage silicon stack to provide DC high-voltage test power supply, with a control box ,automatic protection micro-ammeters, gap and other ancillary equipment. Especially suitable for testing at field, so that heavy work becomes convenient, rapid, easy and flexible, efficiency is greatly improved. As a result, it is well received by power systems and large test workers at large factories and mines.

## 2. Structure

This series are entirely new in design concept, material selection and process flow, so as to minimize volume and reduce weight without reducing performance.

This series use of advanced production equipment, CD type iron core coil winding epoxy vacuum casting and winding with high quality cold-rolled silicon steel, effectively weakening the magnetic leakage, do DC voltage test without external silicon pile, only the DC high voltage silicon company supporting the stack installed in the high voltage side can be obtained dc.

## 3. Advantage

- 1.Epoxy resin vacuum casting and CD type iron core structure technology
- 2.Small size, light weight and compact structure, noleakage, maintenance free;
- 3.Simple wiring, easy to use;
- 4.Reliable Insulation, beautiful appearance;
- 5.Over voltage protection function

## 4. Technical data

- Capacity : 3kVA
- Output voltage: AC:0-50KV
- Output current: AC 0-60mA;
- Surface temperature-raising: < 55°C
- No-load current: < 4%
- Continuous working time: ≤1 minutes
- Output voltage waveform: sine wave,power frequency

## 5. Working principle

The series input voltage 200V or 400V supporting access control box, the autotransformer to adjust the input voltage to test the transformer primary winding (low voltage), based on the principle of electromagnetic induction in the secondary winding (high pressure) to obtain the output voltage according to the ratio of the same ratio with the primary winding

turns, from the highest value to zero volts continuous rated. In DC voltage test and leakage current test, as long as the high voltage silicon stack is installed on the high voltage output terminal, the DC high voltage can be obtained, and its amplitude is 1.414 times of the high frequency power value.

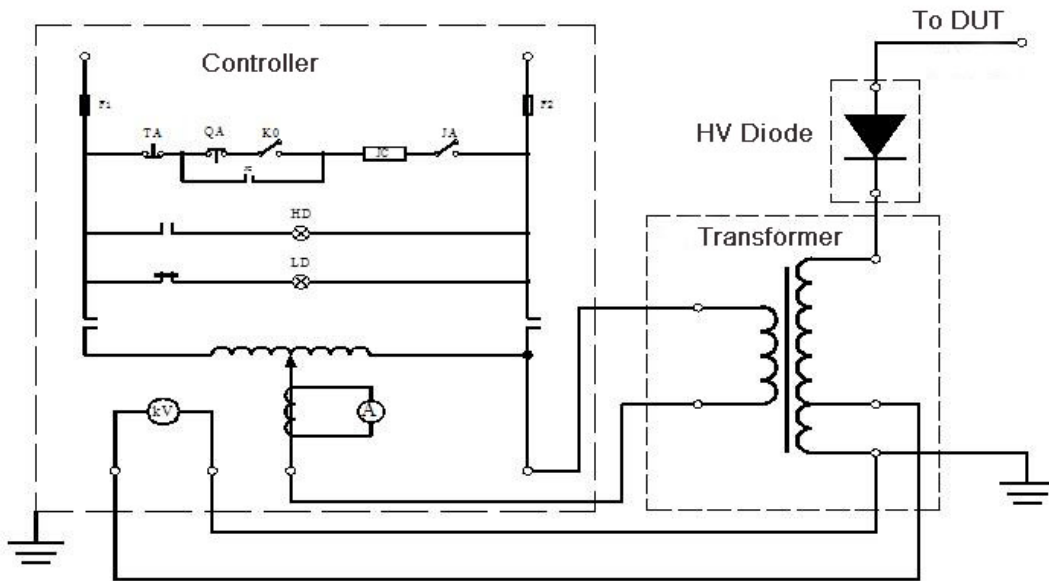

## 6. Pay attention

1) Connect the work line according to your ongoing experiments. The crust of experimental transformer and operating system must earthing reliably. The X end (high voltage tail) of experimental transformer high-voltage winding and the F end of measuring winding must earthing reliably.

2) When doing cascade testing, the low-voltage windings' X-side of the second grade and third grade test transformer, the F-side of measurement windings and high-voltage windings' X-side (high pressure tail) are all connected to the shell of the test transformer. The second grade, third grade test transformer' bracket shell must be grounded through the insulation.

3) Connected to power before the voltage regulator of the operating system must be zero to be connected, switched on, beginning to step up.

4) Start from zero to step up by pressure regulator, Step-up method: rapid step-up method, Step-up method that is level 20s; Slow Step Method, Step-up method that is level

60s, A very slow step-up method for the selection of. Voltage step-up from scratch by a certain way and at a rate up to your desired test voltage rating of 75% in 2% per second at the rated voltage of the speed test you need to rise to the rated voltage And pay close attention to the direction of measuring instruments as well as the test case goods Step-up the process or testing the process of measuring instruments, such as found in the instructions and sample cases were abnormal Blood pressure should be immediate,Cut off the power supply, the identification of the situation.

5) After the test,it should be uniform within seconds of the regulator to return to zero, and then cut off the power

6) This product is used must not exceed the rated parameters. In addition to the pilot to be outside and will never allow full voltage electricity or power.

7) The use of the product high-voltage test, the familiar with the specification, but also to strictly enforce the state standards and procedures. Reference to GB311-83 "high-voltage transmission line with variable insulation equipment, high voltage test technique"; "of preventive tests electrical equipment point of order" and so on.

## 6. Operation condition

- 1.Environmental temperature :0-40 °C;
- 2.Altitude: <1000m;
- 3.Relative humidity: <85%;
- 4.Workplace should be no gas, steam, chemical dust which seriously affect the insulation and other explosive and corrosive media.

## 7. Storage

The product should be placed in ventilated, cool and dry cleaning position, Pay attention to moisture, prevent corrosive gas.